

DURA GOAL INSTALLATION INSTRUCTIONS

Two-Stud Mount

Mounting your hoop to a wall involves a few key steps to ensure it is secure and level. This hoop mounts to two studs in your wall using four keyholes on the wall brackets (see image).

Portions of this process may be easier with two people.

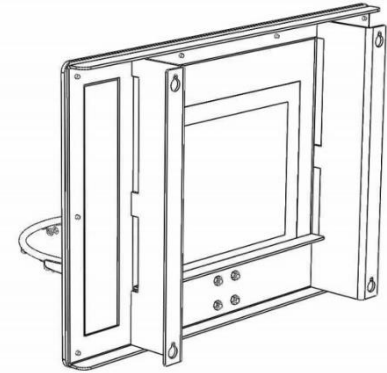



WARNING

Although the rim and backboard are very strong, they are **NOT** designed for hanging. The rim is designed to safely flex 2" at the front of the rim. **NEVER HANG ON THE RIM – THIS WILL VOID YOUR WARRANTY. DO NOT ADJUST THE TENSION ON YOUR SPRING.**

What's Included

Backboard	Rim	Net	Rubber Ball
-----------	-----	-----	-------------

Hardware Included

(4) Rim Screws		(4) Rim Lock Nuts		(4) Lag Screws	
----------------	---	-------------------	---	----------------	---

Tools Required

Phillips screwdriver	7/16" wrench/socket	3/8" wrench/socket	
Stud finder	Level		
Drill	3/16" Drill bit		

Step 1: Attach the Rim

1. Lay the hoop on a flat surface.
2. Hold the rim on the backboard and align the four rim holes (may need two people).
3. Use the four Phillips head screws and lock nuts to attach the rim.
 - a. Hold a nut on the back side of the frame, then insert a screw and turn it until the threads engage.
 - b. Align rim and tighten all rim screws

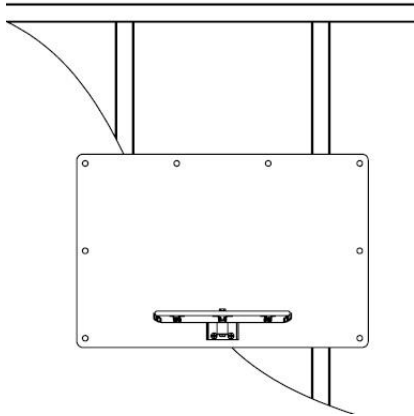
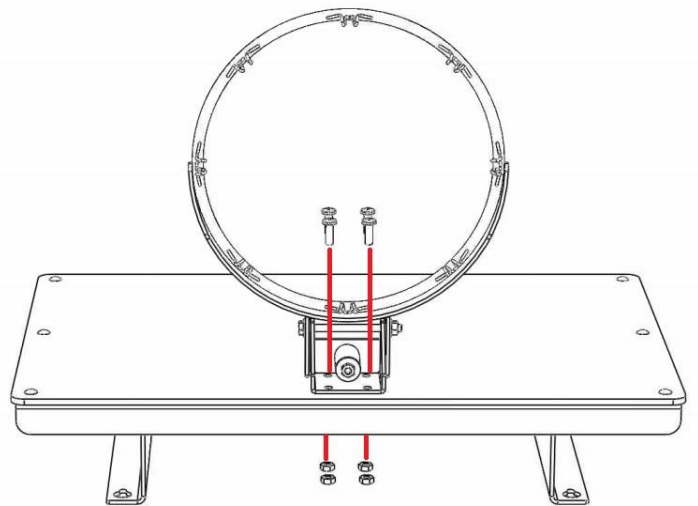

Step 2: Measure and Mark

1. Locate two studs in your wall using a stud finder.
2. Lightly mark each side of the stud locations with a pencil
3. Determine your desired rim height allowing 18" – 24" between the rim and ceiling. Example: With 8' ceiling, use a 6' rim height.
4. Add 12" to your rim height from step 3 to get the top mounting hole dimension.
5. On one stud, measure up from the floor to locate the top mounting hole. Mark the center of this stud.

Step 3: Mount the Hoop

1. Use a 3/16" drill bit to drill one top hole. Verify that you drilled into a stud
2. Install one top mounting screw - leave 1/4" between screw head and wall
3. Hang the top keyhole of the hoop on the mounting screw
4. Use a level on the top of the frame to level the hoop
5. Mark the other three mounting holes by tracing the narrow keyhole slot (or use tip of lag screw)
6. Drill the other three mounting holes
7. Install the other three mounting screws - leave 1/4" between screw head and wall
8. Hang the hoop on all mounting screws
9. Tighten mounting screws
10. Attach the net by attaching the long loops to the rim eyelets

