

MINI BASKETBALL HOOPS BY JUSTINTYMESPORTS



Model: Mini Pro XTreme

Thank you for purchasing a Mini Basketball Hoop by JustinTymeSports! You have just purchased a very unique, high-quality, miniature basketball set that should provide you many years of fun basketball play.

Unpacking Instructions:

Your new mini basketball hoop has been carefully packed to prevent damage. Please verify that you have received all of the components shown on the parts list (see last page).

Assembly Instructions:

Your Backboard and Rim have been pre-assembled at the factory. You will only need to attach the Rim and the Brackets.

It is easiest to assemble the unit prior to mounting the hoop to a wall. It also helps to have a support such as a small box to hold the top of the backboard during assembly. You will need a phillips head screwdriver and an adjustable wrench or pliers.

I. Upper Bracket Assembly

1. Assemble the Upper Support bracket and Support Arms using (2) of the #10-24 x 1/2" screws and (2) Locknuts.

Note: The Upper Support Arms attach on top of the Upper Support Bracket.

2. Attach the Upper bracket Support Arms to the frame using (2) of the #10-24 x 1" Frame Screws and (2) Locknuts. The Support Arms attach to the 2nd and 4th hole in the top of the frame. See Figure 5.

Note 1: The Upper Support Arms attach below the Inner Frame.

Note 2: Use caution so the wrench does not scratch the backboard. You can use a small piece of cardboard to protect the backboard while holding the nuts with the wrench.

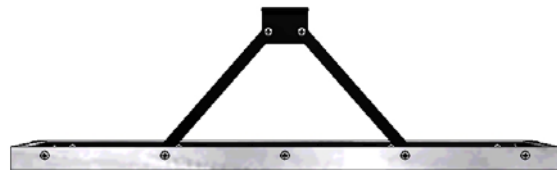

Figure 5

II. Rim and Bracket Assembly

1. Set the Lower Bracket on a flat surface with the four holes facing up. See Figure 6.
2. Set the Backboard Assembly on the Lower Bracket while using the Upper Bracket to support the top of the backboard.
3. Set the Rim on the Backboard Assembly and insert the first 1-1/4" Rim Screw. Use a screwdriver to turn the screw a couple turns - do not tighten at this time.
4. Insert the rest of the 1-1/4" Rim Screws. Tighten all of the screws so the Pads are slightly compressed.
5. Install the Net. The knot (at the bottom of the net) should be located at the back. See Figure 7.

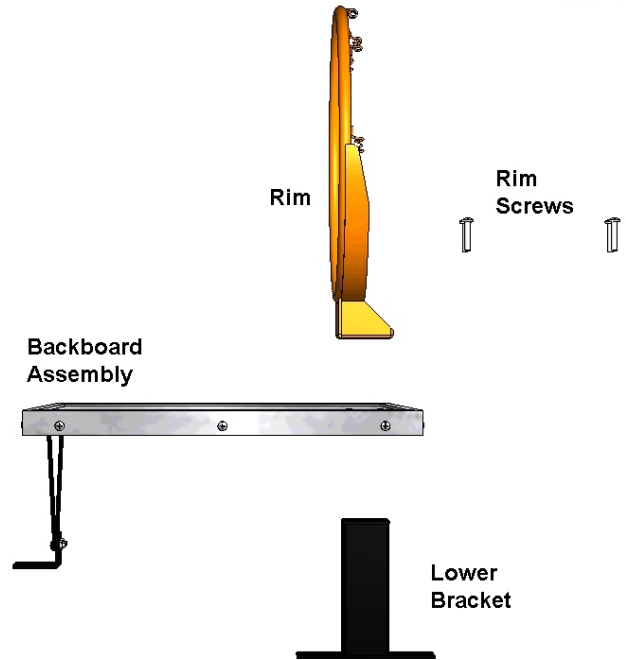

Figure 6



Figure 7

III. Backboard Pad Assembly

1. Install the outside backboard pads. The outside pads have a hole in them to fit over the frame screws. The front of the pads should be flush with the front of the aluminum frame. See Figure 8.
2. Install the front backboard pads. These do not have holes in them. Align the top of the Front Side Pad with the Side Pads.

Your hoop is now ready to be mounted.

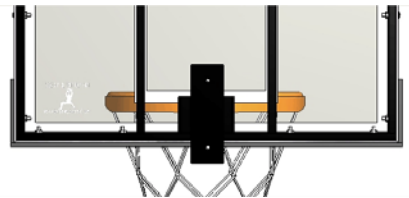

Figure 8



Figure 9

Drill two holes for the Lower Bracket and one hole for the Upper Bracket. Mount using the three Bracket Screws provided (screws are long enough to mount through ½" drywall). You can use bar soap on the bracket screws as a lubricant so the screws will turn in easier.

V. Mounting the Hoop

The mounting bracket is designed to mount to a sturdy structure such as a 2x4 stud in your wall - you should locate the CENTER of the stud for the most secure mounting..

Note: The holes in the bottom bracket are 4" apart. The distance from the top hole of the Lower Bracket to the Upper Bracket hole is 12-1/2". See Figure 10.

You will need a 3/16" drill bit, 7/16" wrench, and a phillips screw driver for mounting and adjusting. You will also need some soap to act as a lubricant for the lag screws.

1. Locate the CENTER of the wall stud using a stud finder.
2. Determine the desired rim height. _____
Add 1" to the rim height for the top hole of the Lower Bracket.
Locate the bottom bracket hole 4" below the top hole.
Locate the Upper Bracket hole 12-1/2" above the top hole of the Lower Bracket.
3. Drill three holes using the 3/16" drill bit.
4. Lubricate each of the lag screws with soap before proceeding. This will help when tightening the screws.
5. Hold the hoop in place and insert the lag screw with washer for the upper hole of the Lower Bracket. Do not tighten completely.
6. While making sure the hoop is level, insert the lag screw and washer in the bottom hole of the Lower Bracket. Do not tighten completely.
7. Double check that the hoop is level. Then insert the lag screw and washer in the Upper Bracket.
8. Tighten all mounting screws.

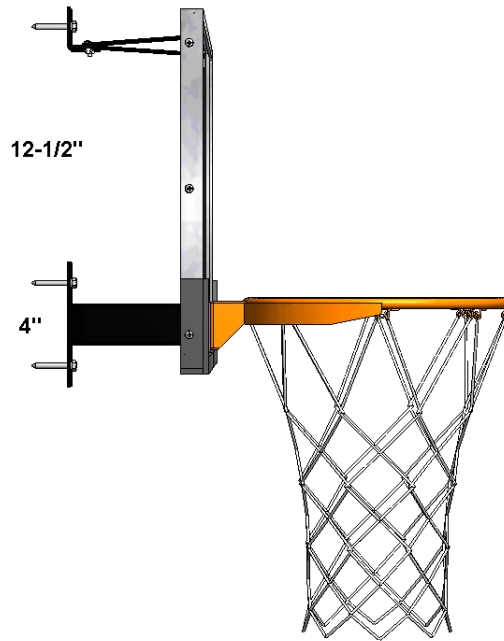

Figure 10

Caring for your backboard:

Your backboard is made from poly-carbonate which is known for its durability and break resistance.

Wash your backboard with mild soap and water. Use a clean soft cloth, applying only light pressure. Rinse with clear water and dry by blotting with a damp cloth or chamois. Do not use window cleaning sprays, kitchen scouring compounds, or solvents.

Mini Pro XTreme Contents:

(1) Backboard Assembly (1) Lower Wall Bracket (1) Upper Wall Bracket (2) Upper Support Arms (1) 1/4" x 1" x 12-1/4" Left Bottom Pad (1) 1/4" x 1" x 12-1/4" Right Bottom Pad (1) 1/4" x 1" x 4" Left Side Pad (1) 1/4" x 1" x 4" Right Side Pad (2) 1/4" x 3/4" x 11-1/2" Front Bottom Pads (Left/Right) (2) 1/4" x 3/4" x 4-1/4" Front Side Pads (Left/Right)	(1) Rim Assembly (1) Net (1) Mini Basketball (4) 1/4-20 x 1-1/4" Rim Screws (2) #10-24 x 1/2" Support Arm Screws (2) #10-24 Self Locking Nuts (3) 1/4" x 2" Bracket Screws (Lag) (3) 1/4" Washers
---	--

JustinTymeSports, LLC
Grand Rapids, MI 49508
www.justintymesports.com
© Copyright 2010